

| PRODUCT # | VOLUME (US GAL) | STEEL THK. (gauge) | A | B | C | D | E | F | G | H | J |
|-----------|-----------------|--------------------|------|-----|-----|-----|-----|-----|-----|----|--------|
| 30119232 | 300 | 12 | 71½ | 29½ | 38¾ | 58 | 27 | 45¼ | 33¾ | 0 | 3" NPT |
| 30209353 | 500 | 10 | 71½ | 29½ | 50¾ | 58 | 33½ | 57 | 33¾ | 0 | 4" NPT |
| 30399333 | 1000 | 10 | 129½ | 50 | 50¾ | 108 | 33½ | 57 | 37¼ | 50 | 5" NPT |

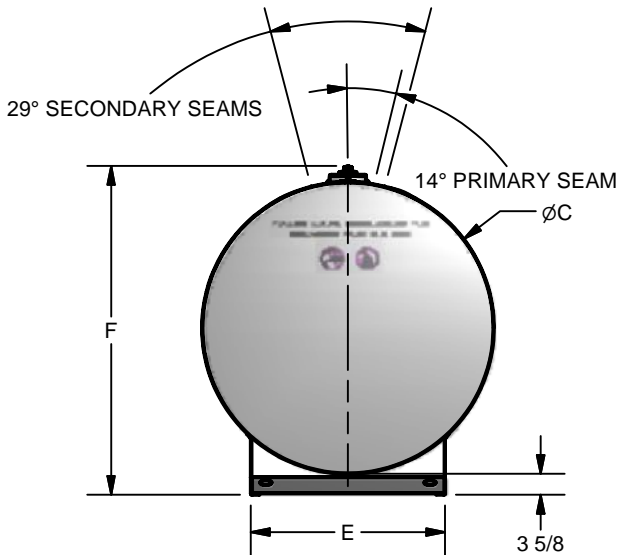
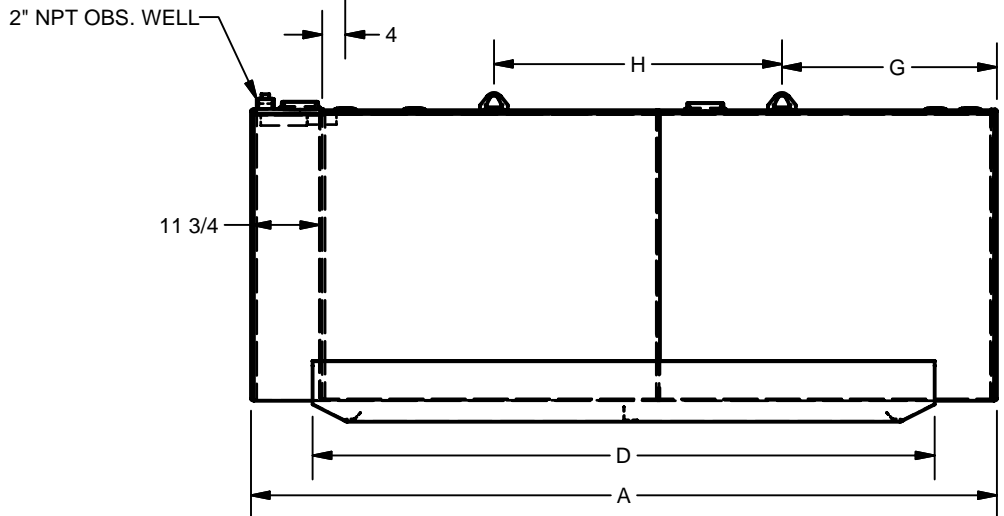
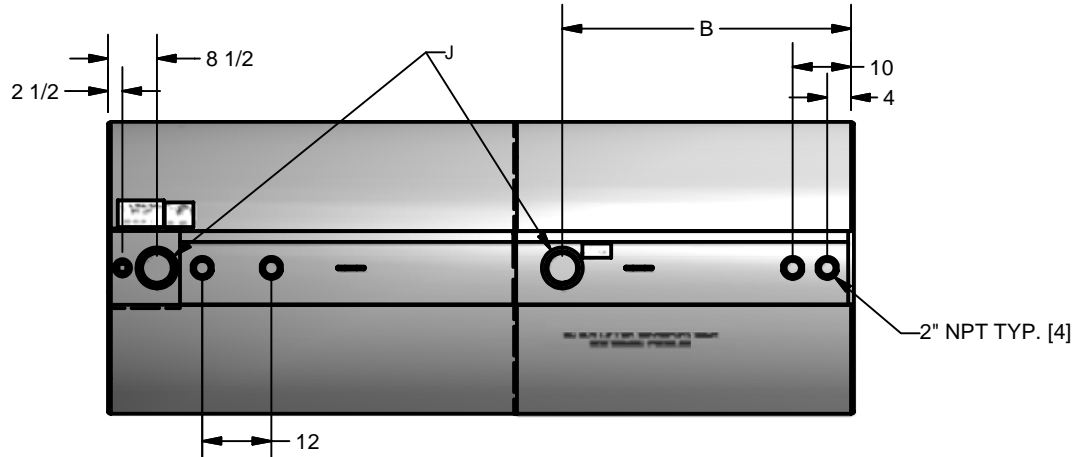

| | | | | | |
|---|--|---|--|---|--|
| This drawing is the exclusive property of Granby Industries Limited Partnership. No part of this drawing may be used or reproduced in any manner without written permission from Granby Industries Limited Partnership | | | | | |
| LINEAR STD TOLERANCES 0 OR FRAC. (X/X) → ±0.5" 0.00 → ±0.125" 0.0 → ±0.25" 0.000 → ±0.0625" | | REVISION DESCRIPTION DRAWN BY E Bourassa 2006-12-11 | | Granby Steel Tanks © 2006 GRANBY INDUSTRIES LIMITED PARTNERSHIP SIZE: A PART NO: SI0054 REV: A | |
| ANGULAR STD TOLERANCES 0 → ± 2 DEG. 0.0 → ± 0.5 DEG. 0.00 → ± 0.1 DEG. | | VERIFIED BY E Bourassa 2006-12-11 | | TITLE UL-142 DOUBLE WALL SKID TANKS | |
| Tank welds must respect SI-0039 specifications | | APPROVED BY J Lacroix 2006-12-11 | | UNITS: INCHES SCALE: 0.05 : 1 SHEET 1 OF 1 | |

2

1

2

1

DA-TANK_TMLPT-A