

TABLEAU DÉCRIVANT LES DIGITS 1 À 5 DU # DE PRODUIT - TABLE DESCRIBING DIGITS 1 TO 5 OF PRODUCT NUMBER

# PRODUIT / PRODUCT #	VOLUME(L,GAL)	POIDS APPROX. / APPROX. WEIGHT	NOMINAL STEEL THK.	PORT D'OBSERVATION / MONITORING	A (in)	B (in)	C (in)	D (in)	E (in)
14830_	680, 150	202 Lb / 92 Kg	2.3 mm	FLOTTE / FLOAT	16	21	45	34	
14930_	910, 200	249 Lb / 113 Kg	2.3 mm	FLOTTE / FLOAT	16	21	60		1/2
14030_	1135, 250	287 Lb / 130 Kg	2.3 mm	FLOTTE / FLOAT	16	21	72		1/2

TABLEAU DÉCRIVANT LE 6IÈME DIGIT DU # DE PRODUIT - TABLE DESCRIBING DIGIT 6 OF PRODUCT NUMBER

# PRODUIT / PRODUCT #	H (in)	K (in)
_____0		1/2 NPT
_____1	1/2 NPT	
_____2		2 NPT
_____3	2 NPT	

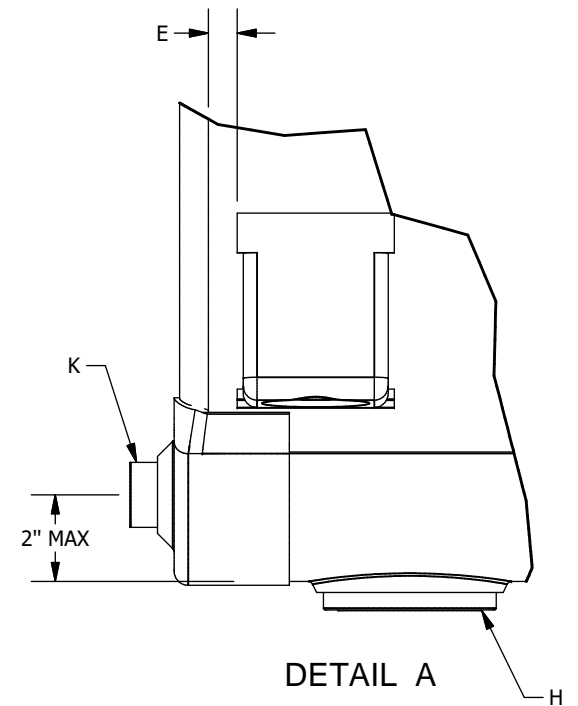
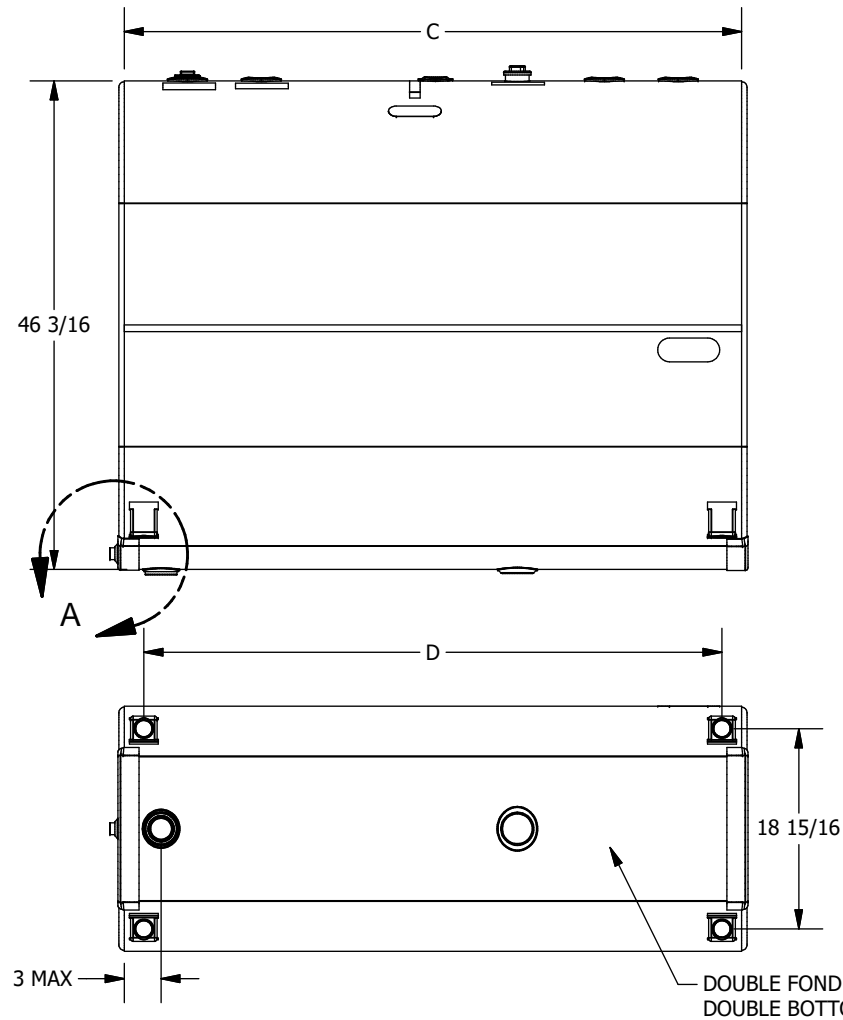
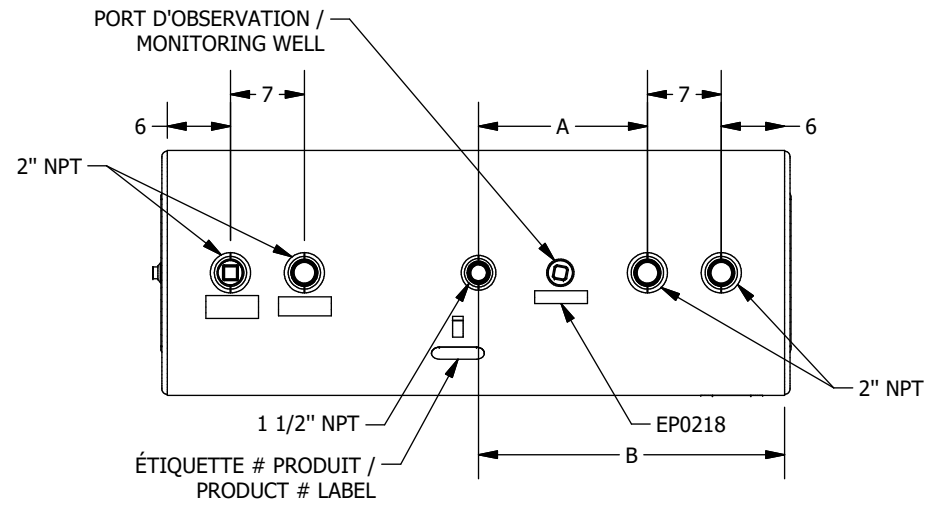
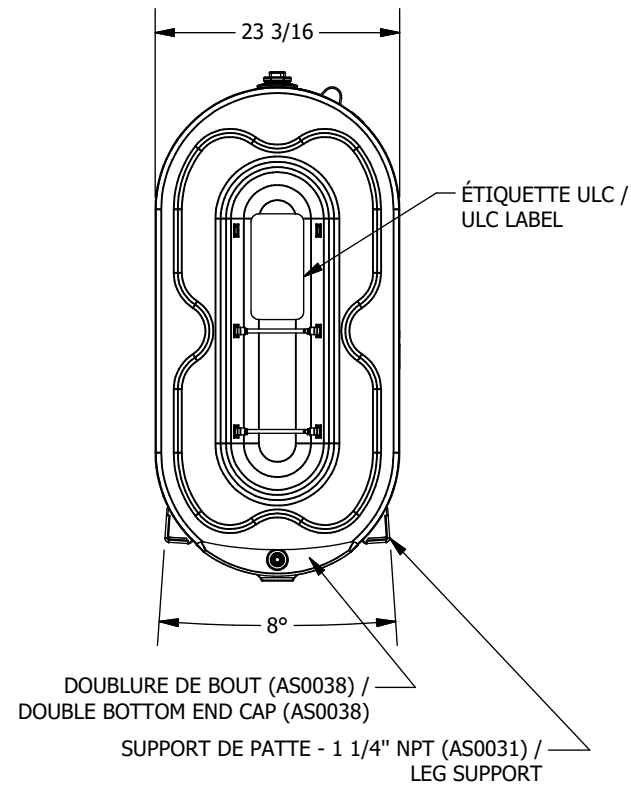

Ce dessin est la propriété exclusive de Industries Granby, SEC. Aucune partie de ce dessin ne peut être utilisée ou reproduite sans sa permission écrite.
This drawing is the exclusive property of Granby Industries LP. No part of this drawing may be used or reproduced in any manner without its written permission.

TOLÉRANCES LINÉAIRES, LINEAR STD TOLERANCES 0 OR FRAC. (X/X) -> ±0.5" 0.00 -> ±0.125" 0.0 -> ±0.25" 0.000 -> ±0.0625"	Description de la révision / Revision description		Industries Granby S.E.C., Granby Industries L.P. © 2018 Industries Granby, SEC. Granby Industries LP	
TOLÉRANCES ANGULAIRES, ANGULAR STD TOLERANCES 0 -> ± 2 DEG. 0.00 -> ± 0.1 DEG. 0.0 -> ± 0.5 DEG.	Dessiné par / Drawn by S. Potvin	12/04/2018	Format / Size B	No de la pièce / Part no. SI0180
Les soudures doivent respecter la spécification SI-0039. Tank welds must respect SI-0039 specifications.	Approuvé par / Approved by :		REV 01	
Poids Approx. / Approx. Weight VOIR TABLEAU / SEE TABLE	Unités / Units INCHES	Echelle / Scale	Feuille Sheet	1 / 1
			Description / Title RÉSERVOIRS OBLONG DOUBLE FOND ALIMENTATION PAR LE DESSUS - ULC-S602 - OBLONG DOUBLE BOTTOM TOP DRAW TANKS	